

POWDER DISSOLVERS

EMT 4-5-6

TECHNICAL FEATURES

DATA	U.M.	EMT 4	EMT 5	EMT 6
Electric power	kW	7,5	11	18,5
Bathtub capacity	l	500	1000	1500
Weight	N	3237	5641	9810
Melting ability	kg/h	400	800	1600
Air pressure included	bar	6	6	6
Air consumption included	nl/h	20	20	20
Water pressure	bar	4	4	4
Water consumption	l/min	400	500	600

STRUCTURAL FEATURES

- A unit with vertical pump here the shaft works overhanging without the bottom bushing and allows them to work on a dry condition.
- The tank is in stainless steel AISI 304.
- Electro-pneumatic butterfly valves with lens in stainless steel AISI 316
- Transmission tube in abrasionproof rubber.
- A new weighing system allows to achieve the correct dosage of liquid and powders with ease

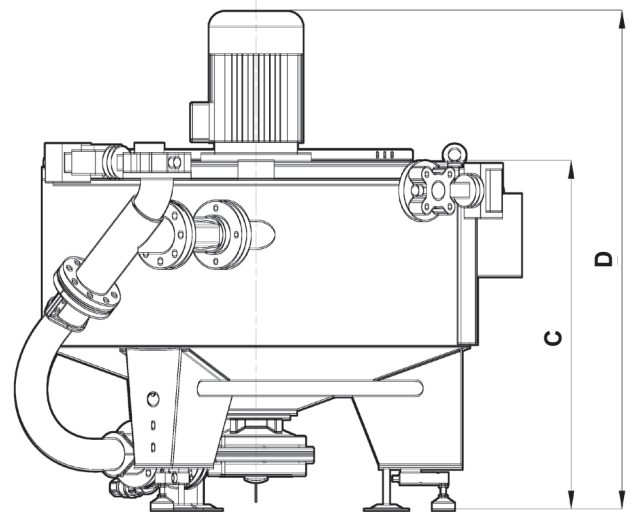
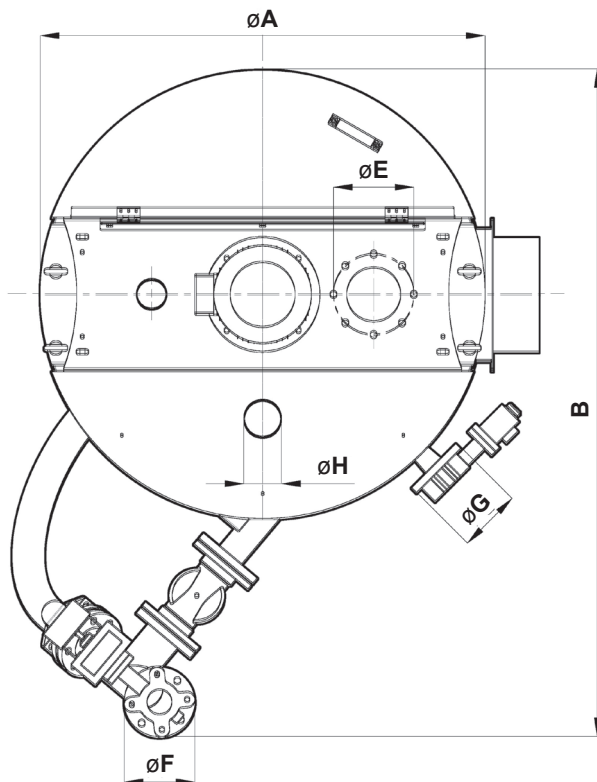

Mod./Size	A	B	C	D	E	ØF	ØG	ØH
EMT 4	1162	1743	947	1355	DN125	DN65	DN50	100
EMT 5	1506	2088	1182	1672	DN125	DN65	DN50	100
EMT 6	1700	2354	1324	1884	DN125	DN80	DN65	120

USE

- At the filters discharge.
- To break down different powders.

ACCESSORIES AND VERSIONS

- Dosage unit impeding flocculation

The information is approximate - The guaranteed values are released by Vibrotech s.r.l. on request - It is forbidden to reproduce the document even partially.



Via Don Pasquino Borghi, 4
42013 S. ANTONINO DI CASALGRANDE (RE)
Italy
Tel. +39 0536 82.37.76
www.vibrotech.biz - email: info@vibrotech.biz

CONTACT FRANCE

Tél. + (33) 1 41 15 91 41
www.tamis-vibrant.fr
contact@tamis-vibrant.fr



**TAMIS
VIBRANT**
INDUSTRIEL