

MILL DISCHARGE TRAILER-MOUNTED UNIT

TSE 800 - 900 - 1200 - 1500

TECHNICAL FEATURES

DATA	U.M.	1500	1200	900	800
Number screening nets	n.	1			
Screening surface	m ²	1.575	0.932	0.587	0.36
Power	kW	2,75+0,3	1,25+0,3	0,73+0,3	0,48+0,3
Centrifugal force	N	25.000	12.753	10.300	6670
Pneumatic pump		2"	2"	2"	2"
Max operating pressure	bar	3			
Max operating temperature	°C	80			
Weight	kg	490	420	380	325

STRUCTURAL FEATURES

- AISI 304 stainless steel frame
- Parts in contact with the product: AISI 304 L – roughness $\leq 0.5 \text{ Ra}_{\mu}$
- Protection rating: IP65
- High-gradient electromagnetic metal separator
- Pneumatic pump to convey enamel

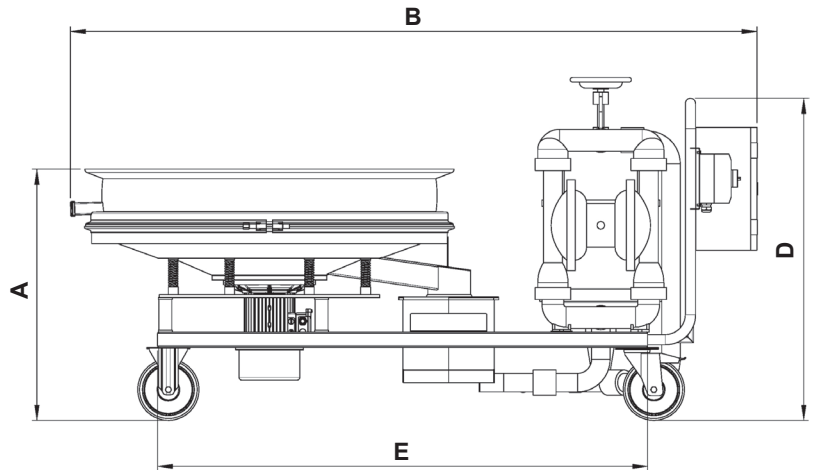
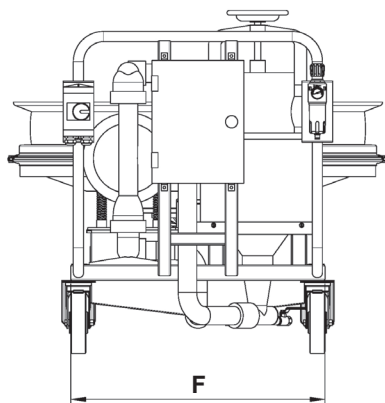

Mod./Size	A	B	C	D	E	F
TSE 800	700	1990	890	942	1465	830
TSE 900	763	2133	1020	996	1600	
TSE 1200	830	2240	1240	996	1600	
TSE 1500	892	2693	1580	996	1850	

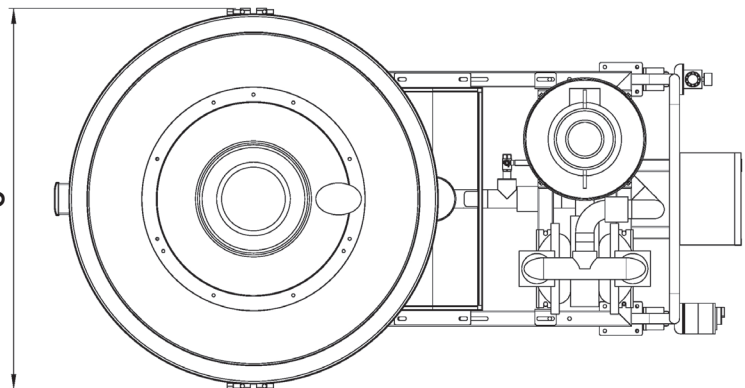

USE

- Screening of enamel coming out of the mills

The information is approximate - The guaranteed values are released by Vibrotech s.r.l. on request-It is forbidden to reproduce the document even partially.



Via Don Pasquino Borghi, 4
42013 S. ANTONINO DI CASALGRANDE (RE)
Italy
Tel. +39 0536 82.37.76
www.vibrotech.biz - email: info@vibrotech.biz

CONTACT FRANCE

Tél. + (33)1 41 15 91 41
www.tamis-vibrant.fr
contact@tamis-vibrant.fr



**TAMIS
VIBRANT
INDUSTRIEL**